

Pb Free Plating Product

LM7805K/LM7812K/LM7815K



THINKISEMI 1.0 AMPERE POSITIVE THREE TERMINAL REGULATOR

<p>Features</p> <ul style="list-style-type: none"> ※ Output current to 1.0A ※ Thermal overload protection ※ Short circuit protection ※ Output transition SOA protection <p>Application</p> <ul style="list-style-type: none"> ※ Switching Regulators and Amplifiers ※ AC and DC Motor Controls ※ Inverters, Solenoid and Relay Drivers <p>Mechanical Data</p> <ul style="list-style-type: none"> ※ Case: TO-3 metal package ※ Operating Temperature Range -65 to +300 °C ※ Terminals: Solderable per MIL-STD-202 method 208 ※ Polarity: As per configuration ※ Mounting position: Any ※ Weight: 6.0 gram approximately 	<p>TO-3/TO-204AE outline</p> 
--	---

Electrical Characteristics LM78xxK

0°C ≤ T_J ≤ 125°C unless otherwise noted.

			LM7805K			LM7812K			LM7815K			Units
Output Voltage			5V			12V			15V			
Input Voltage (unless otherwise noted)			10V			19V			23V			
Symbol	Parameter	Conditions	Min	Typ	Max	Min	Typ	Max	Min	Typ	Max	
	Short-Circuit Current	T _J = 25°C	2.1			1.5			1.2			A
	Peak Output Current	T _J = 25°C	2.4			2.4			2.4			A
	Average TC of V _{OUT}	0°C ≤ T _J ≤ +125°C, I _O = 5 mA	0.6			1.5			1.8			mV/°C
V _{IN}	Input Voltage Required to Maintain Line Regulation	T _J = 25°C, I _O ≤ 1A	7.5			14.6			17.7			V

Absolute Maximum Ratings

Input Voltage (V _O = 5V, 12V and 15V)	35V
Internal Power Dissipation (Note 1)	Internally Limited
Operating Temperature Range (T _A)	0°C to +70°C
Maximum Junction Temperature (TO-3 Package)	150°C
(TO-220 Package)	150°C
Storage Temperature Range	-65°C to +150°C
Lead Temperature (Soldering, 10 sec.) TO-3 Package	300°C
TO-220 Package	230°C

Electrical Characteristics LM78xxK

0°C ≤ T_J ≤ 125°C unless otherwise noted.

				LM7805K			LM7812K			LM7815K			
Output Voltage				5V			12V			15V			
Input Voltage (unless otherwise noted)				10V			19V			23V			
Symbol	Parameter	Conditions		Min	Typ	Max	Min	Typ	Max	Min	Typ	Max	Units
V _O	Output Voltage	T _J = 25°C, 5 mA ≤ I _O ≤ 1A		4.8	5	5.2	11.5	12	12.5	14.4	15	15.6	V
		P _D ≤ 15W, 5 mA ≤ I _O ≤ 1A		4.75		5.25	11.4		12.6	14.25		15.75	V
		V _{MIN} ≤ V _{IN} ≤ V _{MAX}		(7.5 ≤ V _{IN} ≤ 20)			(14.5 ≤ V _{IN} ≤ 27)			(17.5 ≤ V _{IN} ≤ 30)			V
ΔV _O	Line Regulation	I _O = 500 mA	T _J = 25°C	3		50	4		120	4		150	mV
			ΔV _{IN}	(7 ≤ V _{IN} ≤ 25)			14.5 ≤ V _{IN} ≤ 30)			(17.5 ≤ V _{IN} ≤ 30)			V
			0°C ≤ T _J ≤ +125°C	50			120			150			mV
		I _O ≤ 1A	ΔV _{IN}	(8 ≤ V _{IN} ≤ 20)			(15 ≤ V _{IN} ≤ 27)			(18.5 ≤ V _{IN} ≤ 30)			V
			T _J = 25°C	50		120		150		mV			
			ΔV _{IN}	(7.5 ≤ V _{IN} ≤ 20)			(14.6 ≤ V _{IN} ≤ 27)			(17.7 ≤ V _{IN} ≤ 30)			V
0°C ≤ T _J ≤ +125°C	25		60		75		mV						
	ΔV _{IN}	(8 ≤ V _{IN} ≤ 12)			(16 ≤ V _{IN} ≤ 22)			(20 ≤ V _{IN} ≤ 26)			V		
ΔV _O	Load Regulation	T _J = 25°C	5 mA ≤ I _O ≤ 1.5A	10	50	12	120	12	150	mV			
			250 mA ≤ I _O ≤ 750 mA	25		60		75		mV			
		5 mA ≤ I _O ≤ 1A, 0°C ≤ T _J ≤ +125°C	50			120			150			mV	
I _Q	Quiescent Current	I _O ≤ 1A	T _J = 25°C	8		8		8		mA			
			0°C ≤ T _J ≤ +125°C	8.5			8.5			8.5			mA
ΔI _Q	Quiescent Current Change	5 mA ≤ I _O ≤ 1A		0.5			0.5			0.5			mA
		T _J = 25°C, I _O ≤ 1A	1.0			1.0			1.0			mA	
			V _{MIN} ≤ V _{IN} ≤ V _{MAX}		(7.5 ≤ V _{IN} ≤ 20)			(14.8 ≤ V _{IN} ≤ 27)			(17.9 ≤ V _{IN} ≤ 30)		
		I _O ≤ 500 mA, 0°C ≤ T _J ≤ +125°C		1.0			1.0			1.0			mA
V _{MIN} ≤ V _{IN} ≤ V _{MAX}		(7 ≤ V _{IN} ≤ 25)			(14.5 ≤ V _{IN} ≤ 30)			(17.5 ≤ V _{IN} ≤ 30)			V		
V _N	Output Noise Voltage	T _A = 25°C, 10 Hz ≤ f ≤ 100 kHz		40		75		90		μV			
$\frac{\Delta V_{IN}}{\Delta V_{OUT}}$	Ripple Rejection	I _O ≤ 1A, T _J = 25°C or I _O ≤ 500 mA	f = 120 Hz	62		80	55	72	54	70	dB		
				62		55	54	dB					
		V _{MIN} ≤ V _{IN} ≤ V _{MAX}		(8 ≤ V _{IN} ≤ 18)			(15 ≤ V _{IN} ≤ 25)			(18.5 ≤ V _{IN} ≤ 28.5)			V
R _O	Dropout Voltage	T _J = 25°C, I _O = 1A		2.0		2.0		2.0		V			
	Output Resistance	f = 1 kHz		8		18		19		mΩ			

Note 1: Thermal resistance of the TO-3 package (K, KC) is typically 4°C/W junction to case and 35°C/W case to ambient. Thermal resistance of the TO-220 package (T) is typically 4°C/W junction to case and 50°C/W case to ambient.

Note 2: All characteristics are measured with capacitor across the input of 0.22 μF, and a capacitor across the output of 0.1 μF. All characteristics except noise voltage and ripple rejection ratio are measured using pulse techniques (t_w ≤ 10 ms, duty cycle ≤ 5%). Output voltage changes due to changes in internal temperature must be taken into account separately.

Note 3: Absolute Maximum Ratings indicate limits beyond which damage to the device may occur. For guaranteed specifications and the test conditions, see Electrical Characteristics.

Typical Performance Characteristics

Maximum Average Power Dissipation

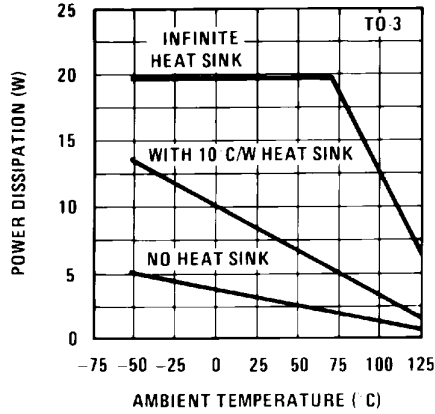

Maximum Average Power Dissipation

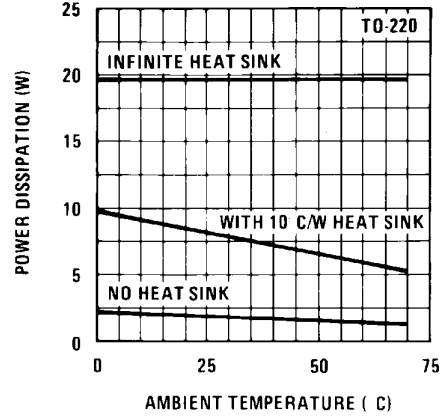

Peak Output Current

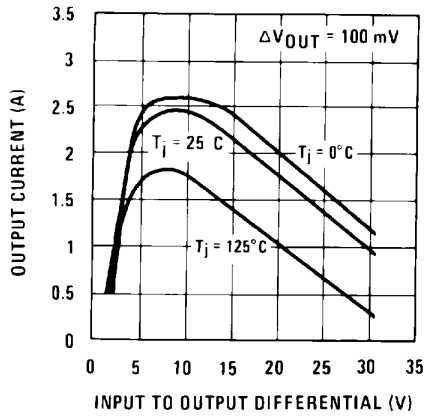

Output Voltage (Normalized to 1V at Tj = 25°C)

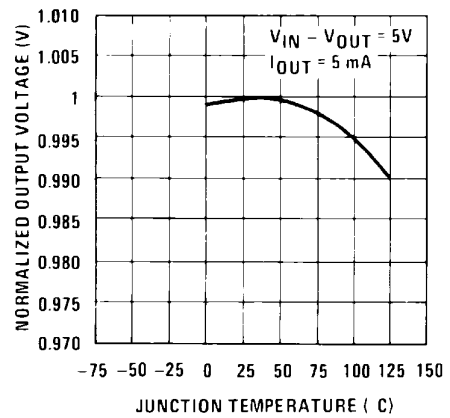

Ripple Rejection

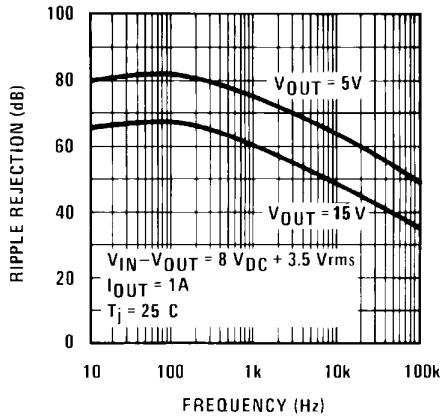

Ripple Rejection

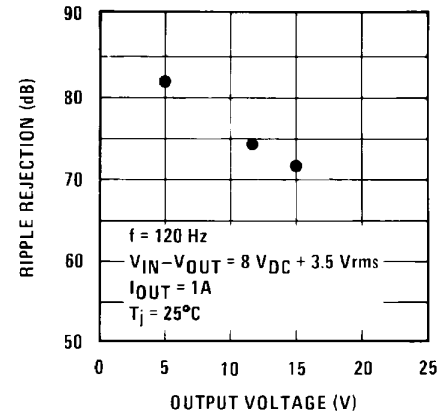

Typical Performance Characteristics (Continued)

Output Impedance

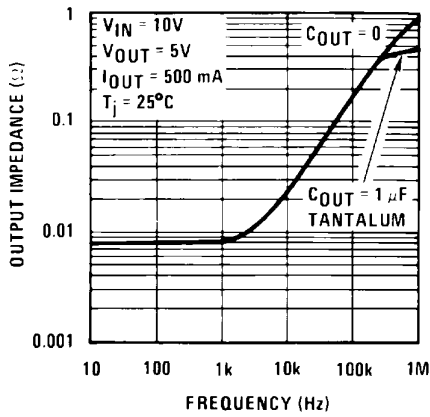

Dropout Voltage

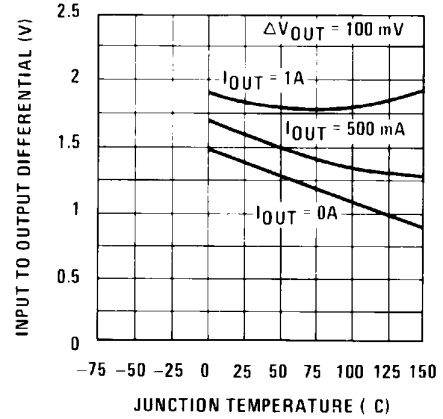

Dropout Characteristics

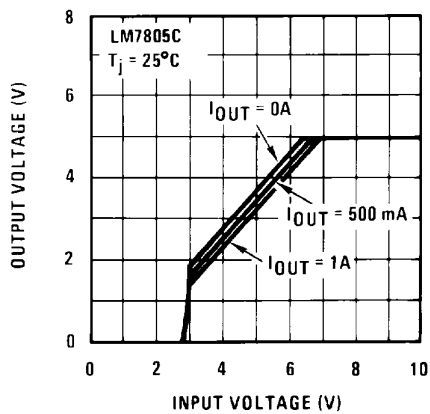

Quiescent Current

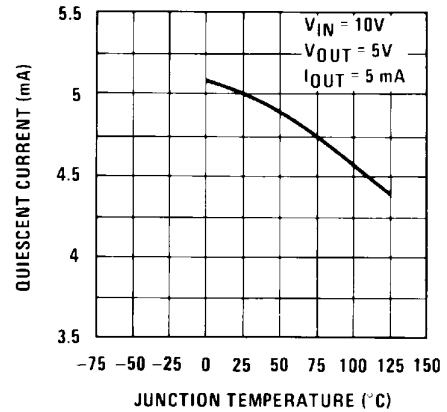

Quiescent Current

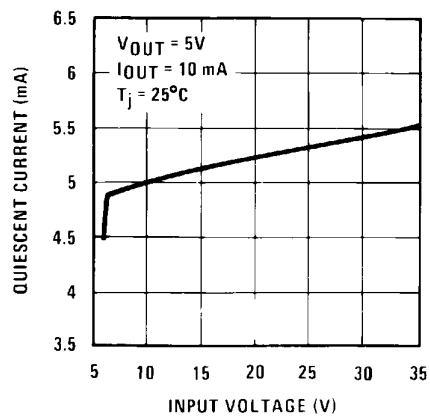

THINKI TO-3 Package Dimensions

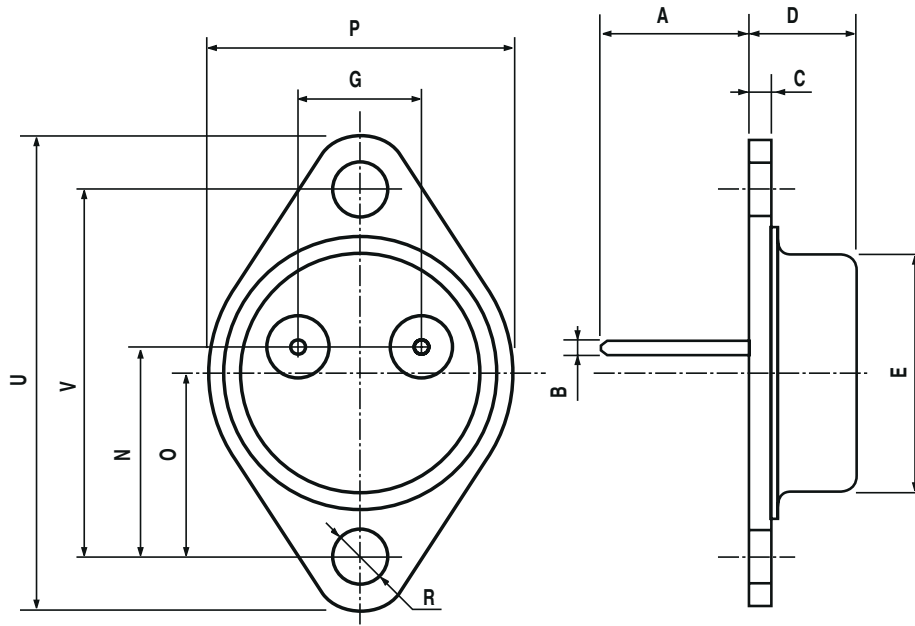

Table 26. TO-3 mechanical data

Dim.	mm.			inch.		
	Min.	Typ.	Max.	Min.	Typ.	Max.
A		11.85			0.466	
B	0.96	1.05	1.10	0.037	0.041	0.043
C			1.70			0.066
D			8.7			0.342
E			20.0			0.787
G		10.9			0.429	
N		16.9			0.665	
P			26.2			1.031
R	3.88		4.09	0.152		0.161
U			39.5			1.555
V		30.10			1.185	